

## The Escape Behavior of the Cockroach *Periplaneta americana*

### I. Turning Response to Wind Puffs\*

Jeffrey M. Camhi and Winston Tom

Section of Neurobiology and Behavior, Langmuir Laboratory, Cornell University, Ithaca, New York 14853, USA

Accepted July 24, 1978

**Summary.** 1. Cockroaches (*Periplaneta americana*) responded to controlled wind puffs with stereotyped turns away from the source of wind. This was followed by running in more varied directions (Fig 3, 5).

2. Control experiments indicate that the wind direction, and not other cues from the wind stimulator, provides the directional information for the turn (Fig. 7).

3. Cockroaches with the ventral surfaces of their cerci covered were unresponsive to controlled wind puffs. However, covering the dorsal surfaces left the responses essentially intact (Fig. 9). Covering the left cercus caused turns to be misoriented to the left (Fig. 11). Rotating both cerci toward the left led to a corresponding misorientation of the turn (Fig. 10). Thus the cockroaches appeared to employ only wind receptors on the ventral surfaces of the cerci (the location of the filiform hairs; Nicklaus, 1965) to detect all directions of wind puff and to evoke the turning behavior.

4. The initial movements of each metathoracic leg in response to wind stimuli depended upon wind angle (Fig. 12). These leg movements were consistent with earlier neurophysiological data on the motor outputs to the legs from giant interneurons which respond selectively to wind from different directions (Ritzmann and Camhi, 1978; Westin et al., 1977).

5. The turning response was properly oriented, and the leg movements properly directed, even when sampled during the first 0–16 ms of movement (Figs. 12, 13). This presumably was prior to the time when feedback from the animal's own turning movement would be available to influence the turn. Thus

the turning behavior may be executed in an open loop manner.

6. These findings are discussed in relation to the role of identified giant interneurons in the oriented evasive behavior, and the possible role of this behavior in nature.

### Introduction

Many animals respond to aversive stimuli with a rapid escape behavior (Bullock and Horridge, 1965). The initial escape movements are most often highly stereotyped and involve only a limited ability to direct the animal away from the source of stimulation. For instance, touching a crayfish anywhere on the thorax or head leads to an initial backward-directed movement produced by a single "tail flip"; touching anywhere on the abdomen leads to upward and forward locomotion, produced by a slightly different tail flip. This either-or aspect of the initial escape movement may represent a sacrifice of directional accuracy for speed of response. The mediation of these two tail flips, each by only a single pair of rapidly conducting giant interneurons, apparently contributes to the stereotypy and limited range of initial movements (Wine and Krasne, 1972).

The cockroach, *Periplaneta americana*, responds to a gentle puff of wind by running (Roeder, 1948). There is evidence that this behavior is also mediated, at least in part, by a group of giant interneurons (Ritzmann and Camhi, 1978). The 14 abdominal interneurons (7 bilateral pairs) with the largest axonal diameters have been individually identified. These, as well as an unknown number of smaller interneurons, are excited by wind-receptive sensory cells (Westin et al., 1977). Each sense cell connects peripherally to one of about 440 filiform hairs located on the ventral surfaces of the cerci—two posterior abdominal appendages (Roeder, 1948; Callec, 1974). The sensory neurons, and 10 of the 14 identified giant

\* The authors dedicate this paper and its companion (J. comp. Physiol. 128, 203–212 (1978)) to Dr. Kenneth Roeder. Dr. Roeder began the detailed study of the mechanisms underlying the cockroach's escape behavior prior to the emergence of invertebrate neuro-ethology as an active field of inquiry (Roeder, 1948). He has approached this and other systems with a unique insight into the neural control of animal behavior under actual field conditions. We are indebted to him for such insights which have helped to shape the studies reported in these two papers

interneurons, are directionally selective in their responses to wind (Nicklaus, 1965; Westin et al., 1977; Westin, in preparation). Therefore, it seemed possible that the cockroach's evasive response to wind may also be directional.

In this paper, we show that the behavioral response of the cockroach to a gentle wind puff begins with a turn away from the source of wind. For all stimulus directions, receptors for air displacement located on the ventral surfaces of the cerci provide the major or only input for the behavior. The initial movements of the metathoracic legs during the turn are predictable from a knowledge of the directional inputs and the motor outputs of specific giant interneurons. Thus the directional information conveyed by the giant interneurons (Westin et al., 1977) is implicated in mediating the turning behavior. The second paper in this series (Camhi et al., 1978) shows that the cockroach can use this wind-evoked turning behavior to escape from the strike of a natural predator.

## Materials and Methods

We used adult male *Periplaneta americana* in all experiments, as in the earlier neurophysiological studies in this laboratory (Westin et al., 1977; Ritzmann and Camhi, 1978). Our breeding colonies of cockroaches were begun originally with commercially supplied adults. The colonies were kept in the laboratory in plastic barrels with screen covers. They were fed on rat chow and water ad lib. Humidity, temperature and photoperiod were not specifically controlled.

For each experiment, one or more cockroaches were placed in an observation chamber and exposed to a wind stimulus (Fig. 1). The observation chamber consisted of a circular floor (1 meter in diameter) surrounded by a plastic wall. To prevent cockroaches from escaping, the wall was coated with a very fine layer of petroleum jelly. There was no indication that the cerci became covered with this lubricant or that the behavior thereby deteriorated. The floor of the chamber was coated with a mixture of sand and paint to provide traction for running. The responses of the animals were filmed through a 45° mirror with a Bolex H 16 reflex camera operated at 64 frames/s. Lighting was provided by an incandescent flood lamp whose intensity at the floor of the chamber was 1500–3000 Lux. The temperature inside the chamber was 24°–29 °C. Behavior was quantified by analyzing individual ciné frames on a Vanguard Motion Analyzer. All angular measurements were accurate to  $\pm 1\frac{1}{4}^\circ$ .

At the beginning of some experiments, 10 cockroaches were placed in the observation chamber and allowed to explore the area for approximately one hour. In other experiments, animals were kept overnight within the observation chamber in individual, inverted plastic cups. The roof of each cup had air holes and the walls were lubricated with a fine layer of petroleum jelly to prevent climbing. Just before the presentation of a wind stimulus to a cockroach, its cup was gently lifted away. After the insect responded, it was again covered with the cup and given a rest of at least 10 min. Insects treated in this way usually remained in place until the stimulus was presented. The wind stimulus was always delivered with the wind tunnel positioned 6 cm from the cerci and only when the animal was standing still or walking very slowly.

The wind tunnel was constructed using 4 fans which forced air into a tube (length=80 cm, diameter=3.8 cm) and through

4 gauze filters which reduced turbulence (Fig. 1). Fan speed was controlled by a rheostat. Passage of the air out of the tube was controlled by a tightly fitting camera shutter (3.8 cm aperture; Ilex No. 4 Acme Synchro). With the shutter closed, the air passed out an evacuation valve pointed away from the animal. The entire wind tunnel was mounted on a cart so that identical wind puffs could be delivered almost anywhere within the observation chamber.

Wind puffs were recorded prior to a series of experiments using a hot wire anemometer (Datametries 800-VTP, Wilmington, Mass.) and were monitored on an oscilloscope (Tektronix 564). The anemometer had a frequency response to air displacement of approximately 0 to 100 Hz. Fixed settings of fan speed, shutter speed, shutter opening, and the amount of opening of the evacuation valve gave reproducible puffs (Fig. 2A). The peak wind speed, 2.0 m/s, was somewhat lower than that used earlier to study the

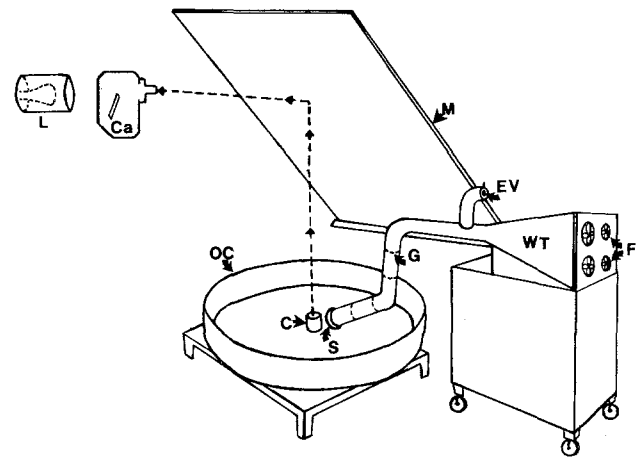

**Fig. 1.** Experimental apparatus. Animals were placed in observation chamber (OC). In some experiments, each cockroach was kept in an inverted cup (C) until the time of wind stimulation. The stimulating wind was produced by the fans (F) of the wind tunnel (WT). When the shutter (S) was opened, wind passed through gauze turbulence filters (G) and out over the animal. When the shutter was closed, wind passed out of the evacuation valve (EV). The camera (Ca) viewed the subject through a 45° mirror (M). Illumination was effectively from above by a tungsten lamp (L). The wind tunnel did not touch the observation chamber

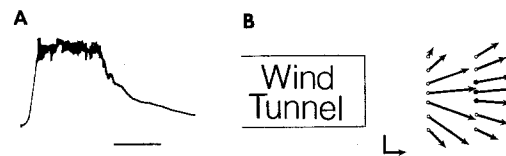

**Fig. 2A and B.** Wind stimulus. **A** Wind speed vs. time, at position of cerci. Stimulus includes turbulence, especially during the plateau. Vertical scale nonlinear: peak wind speed=2.0 m/s. Time mark=100 ms. **B** Map of "wind field". Arrows show mean direction and peak wind speed of stimulus, sampled at various locations in front of wind tunnel. Vertical calibration bar: 1 cm. Horizontal calibration arrow: 1 m/s peak wind speed (refers to length of arrows). Locations of measurement are indicated by circles; filled circles indicate approximate position of animal's cerci just prior to a wind stimulus. The direction of air displacement at each location was measured by observing the deflection produced by the stimulus wind on a 1 mm wax sphere suspended by a fine platinum wire. Local wind speeds were measured with an anemometer

responses of giant interneurons (2.6 m/s; Westin et al., 1977). Also for these behavioral experiments, a wind tube of larger diameter was used in order to reduce the error in directing the wind puff over the cerci of freely moveable insects. The larger tube resulted in wind puffs having greater turbulence and a lower rise time. A map of the "wind field" shows that, in spite of the increased turbulence, the major component of flow in the region of the cerci was essentially parallel to the wind tunnel (Fig. 2B). With the fans turned off, there was no wind resulting from the movement of the shutter blades measurable at the position of the cerci. Furthermore, opening the shutter failed to evoke action potentials in giant fibers of dissected preparations (Westin and Camhi, unpublished) or behavioral responses in intact cockroaches.

**Results**

*Turning Response to Wind*

Casual observations indicated that cockroaches often turned away from gentle puffs of wind. This was borne out by quantitative studies on free-ranging insects. The behavioral responses to stimuli from the wind tunnel typically began with pivots away from the wind source (Fig. 3). The mean latency from the time of shutter opening to the first movement by the cockroach was 62 ms (3.9 frames; n=54). Only 4 ms of this time was occupied by the wind front passing from the shutter to the cockroach's cerci. This agrees roughly with earlier measurements on restrained animals, where the mean was 54 ms (Roeder, 1963). At the start of a response, the body pivoted about a point near its posterior end, so that the head moved away from the source of stimulation. The magnitude of this initial pivot will be called the "angle of turn." This we define as the angle between the animal's position on the cine frame just before any body movement began, and its position on the frame when turning stopped or reversed direction (see darkened arrows, Fig. 3). After the initial pivot, the animal's turning behavior was more variable. For instance, out of 28 initial turns larger than 20°, 14 were followed within the first 1/4 second by a reversal of direction of 10° or larger (e.g. Fig. 3B, 3F).

For all trials, we plotted the angle of turn (i.e. the initial pivot) as a function of the stimulus angle (the initial angle of the animal with respect to the wind tunnel). The conventions used to construct these graphs are shown in Figure 4. The data from normal, free-ranging cockroaches confirmed that the initial movement was oriented away from the source of wind (Fig. 5). However, on most trials, the animals did not turn completely away during the initial pivot, as indicated by the fact that the absolute value of the slope of the regression line was less than one.

Subsequent experiments were simplified by the fact that we could control the position of the cock-

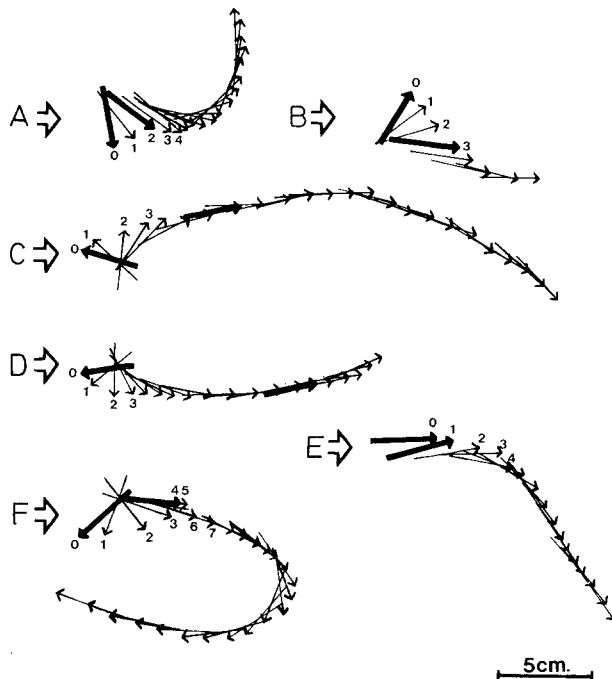

**Fig. 3.** Representative turning responses to wind puffs by free-ranging cockroaches. A-F 6 different trials. For each trial, the sequence of arrows, 0-1-2..., represents the positions of the body (arrows point anteriorly) with respect to the wind tunnel (open arrow) on successive ciné frames, 16 ms apart. Arrow "0" shows the insect's position on the ciné frame just prior to the onset of the turning response. The angle between the two thick arrows for each trial is defined as the "angle of turn" (see text)

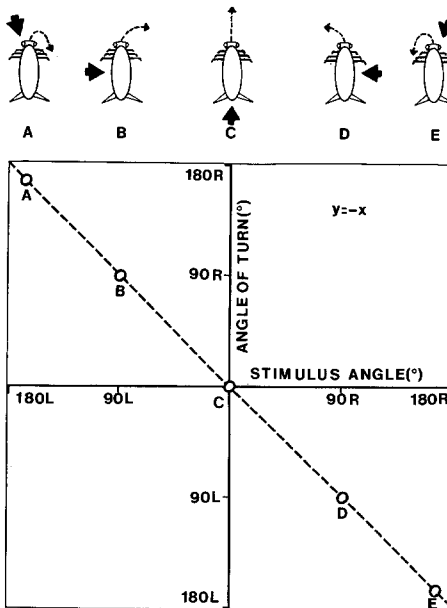

**Fig. 4.** Conventions for plotting angle of turn vs. stimulus angle. For illustrative purposes, the cockroach is assumed to turn exactly away from the wind source. A through E Thick arrows=stimulus angles, 170° L, 90° L, 0°, 90° R, 170° R respectively. Thin arrows=angle of turn, 170° R, 90° R, 0°, 90° L, 170° L, respectively. The regression line for these idealized data points has the formula  $y = -x$

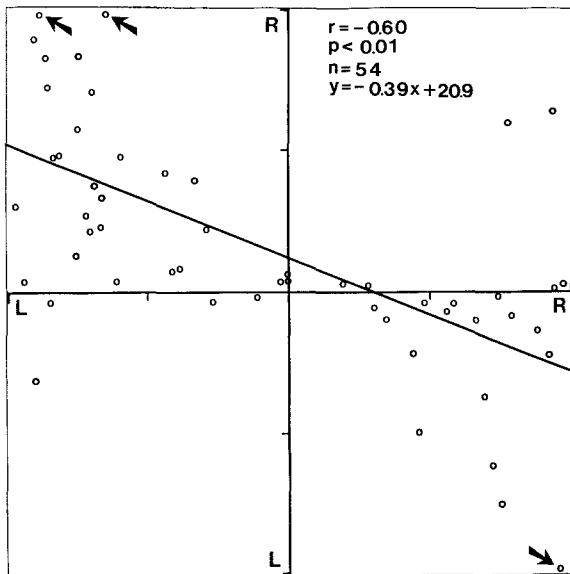

**Fig. 5.** Turning responses of ten free-ranging cockroaches. Angle of turn vs. stimulus angle plotted by the conventions shown in Fig. 4. Each point represents one turning response. Points indicated with an arrow represent turns larger than  $180^\circ$  R or  $180^\circ$  L (all between  $180^\circ$  and  $245^\circ$ ). The regression line has a correlation coefficient ( $r$ ) which is highly significant

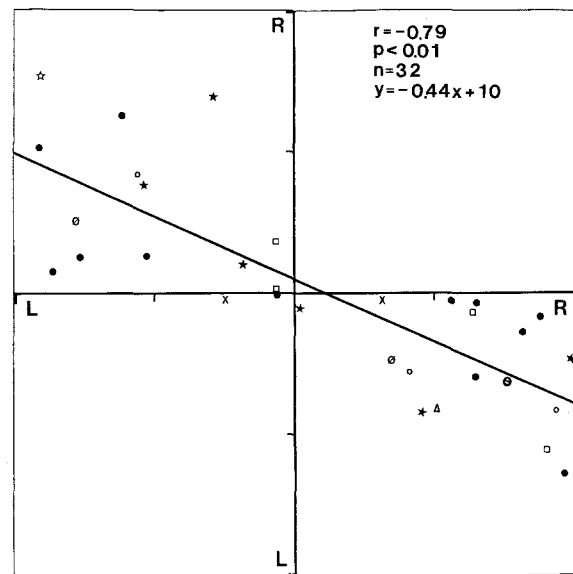

**Fig. 7.** Control for directional cues other than wind. Angle of turn vs. angle of wind from bellows, plotted as in Fig. 4. Animals were kept in inverted cups. Each type of symbol represents the responses of a different animal. See text for details

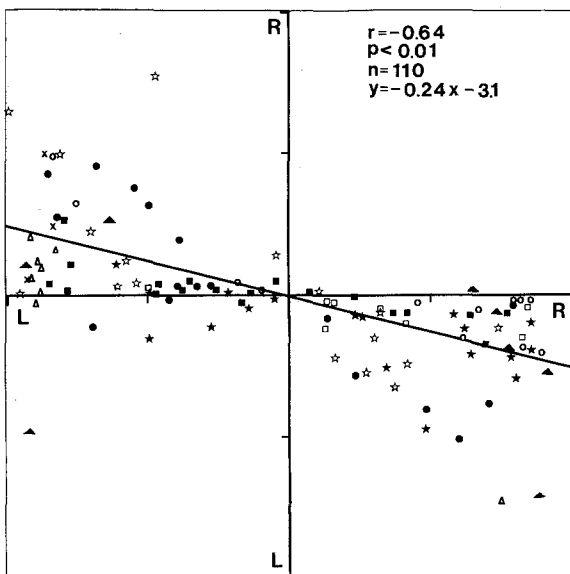

**Fig. 6.** Turning responses of cockroaches kept under inverted cups. Angle of turn vs. stimulus angle plotted by the convention shown in Fig. 4. Each type of symbol represents the responses of a different animal

roach prior to wind stimulation. To achieve this, we used the procedure of keeping each insect overnight under a cup, and covering it again after each trial, as was described in the methods section. Like free-ranging insects, these cockroaches also turned away from the source of wind (Fig. 6). However, their turns

were generally smaller, as shown by the absolute value of the slope (compare Figs. 5 and 6). Also, there was less scatter in the points, and the regression line passed more nearly through the origin than for our sample of free-ranging cockroaches (Fig. 5).

It was necessary to determine whether the wind or some other stimulus evoked the turning behavior. Opening and closing the shutter of the wind tunnel with the fans off, as well as turning on the ciné camera, evoked no movement from the animal. However, it remained possible that the wind provided the stimulus to run, but that other cues determined the direction of the turn. Therefore, we performed an experiment in which essentially all potential cues were the same as before, except that the wind approached the animal from the side opposite the wind tunnel. To achieve this, the fans of the wind tunnel were turned on, but a partition was placed in front of the fans so that when the shutter was opened, no measurable wind passed out of the tunnel. The actual wind stimulus was delivered through another tube. This was a glass tube of 2 cm inner diameter, located 45 cm away, on the opposite side of the animal. This tube presented to the animal a visual angle of less than 1/20th that of the regularly used wind tunnel. The wind delivered through the glass tube was produced by a fireplace bellows. One arm of the bellows was gravitationally loaded, raised to a fixed height, and then released when we activated a solenoid. Although this wind was highly turbulent, the peak speed was

within 20% of the peak speed of the standard puff produced by the wind tunnel. The bellows and the sound-shielded solenoid were almost silent and out of the view of the cockroach.

Most animals responded by turning away from the tube through which the bellows wind was delivered (Fig. 7). This occurred irrespective of the time interval between the arrival of the wind puff at the cockroach and the opening of the shutter on the wind tunnel. (Intervals tested ranged from 150 ms wind-to-shutter to 130 ms shutter-to-wind.)

### Role of the Cerci

Wind-receptive filiform hair cells, known to excite the giant interneurons of the cockroach, are located on the ventral surfaces of the cerci (Nicklaus, 1965; Gnatzy, 1976; Callec, 1974). To determine whether these sensory cells also mediate the turning behavior, we covered the ventral surfaces of both cerci of 6 animals with Eastman 910 adhesive. To control for the application and the presence of the adhesive, we covered the dorsal surfaces of both cerci in 6 other animals. The dorsal surfaces bear numerous receptors but no filiform hairs. Animals with adhesive on their ventral surfaces were totally insensitive to standard wind stimuli. Figure 8 shows the range of angles from which these stimuli were delivered. Surprisingly, even wind puffs from the front of the animal, which one might expect to elicit a movement mediated by receptors on the antennae or body, evoked no response. The responses of animals with adhesive on the dorsal surfaces were essentially normal (Fig. 9). That is, the slope of the regression line of the dorsally covered animals differed by only 0.03, and the Y-intercept by only 5°, from that of the normal animals which had also been kept under cups (Fig. 6).

It remained a remote possibility that the receptors for detecting wind direction are not actually on the cerci. For instance, covering the ventral surfaces of the cerci with adhesive could have blocked some receptors which do not convey directional information, but are necessary to initiate the behavior. The directional cue could then have come from some non-cercal receptors for wind or other cues. Alternatively, the adhesive could have stimulated some receptors which inhibit the evasive behavior. Two tests ruled out these possibilities. First, under light CO<sub>2</sub> anesthesia, we rotated both cerci in the clockwise direction as viewed from above. We then fixed them in their new positions by placing a small drop of slightly warmed wax dorsally at the base of each cercus. Normal cerci protrude backward from the body at an angle of about 60° from the midline. Each is freely

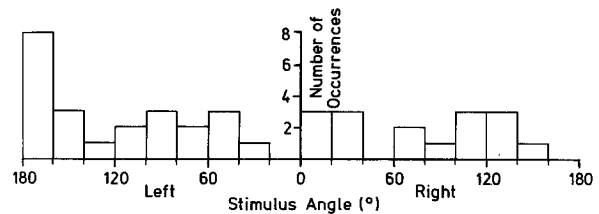

Fig. 8. Angles of wind stimulation presented to cockroaches whose ventral cercal surfaces had been covered. No animal made any detectable movements in response to any stimulus angle presented

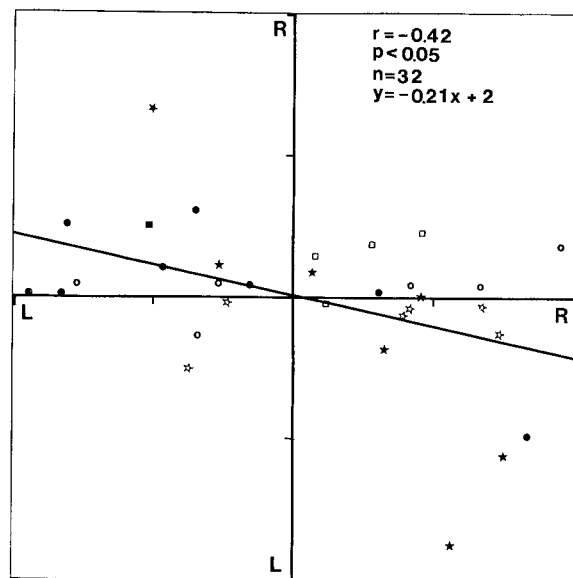
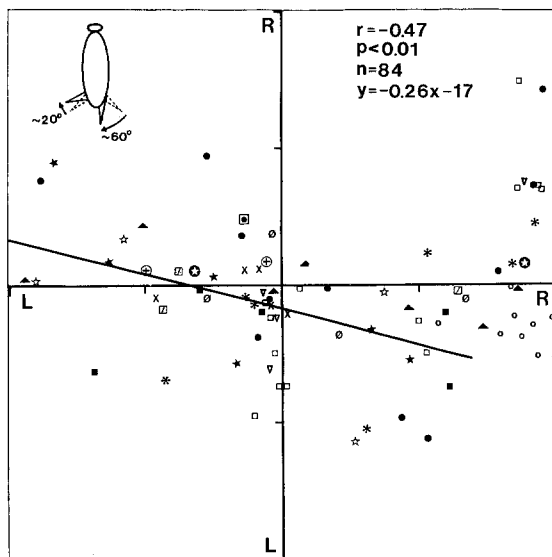

Fig. 9. Control for application of adhesive to cerci. Angle of turn vs. stimulus angles plotted as in Fig. 4. Dorsal surfaces of cerci were covered. Animals were kept in inverted cups. Each type of symbol represents the responses of a different animal

movable backward by about 70°, just beyond the midline. Thus we rotated the right cercus by 60–70°. The lateral socket of the left cercus was cut to allow rotation in the clockwise direction. Even so, the left cercus could only be rotated by 20°–30°.<sup>1</sup>

The graph for animals with rotated cerci suggests that receptors on the cerci, and not elsewhere on the body, direct the turning responses (Fig. 10). The regression line is shifted by about 65° to the left as compared with animals which have been kept under cups and whose cerci have not been rotated (Figs. 6, 9). The slopes for the normal and cercal-rotated animals differed by only 0.02 (Figs. 6, 10). Two aspects of the graph are especially notable. First, wind stimuli from 0° to 20° L would be sensed by receptors located anywhere on the body *except* the cerci as coming from the animal's left. Any such receptors would

<sup>1</sup> Recordings from directionally selective giant interneurons have shown that as the cerci are rotated, the optimal wind direction changes accordingly (Westin, unpublished observations)

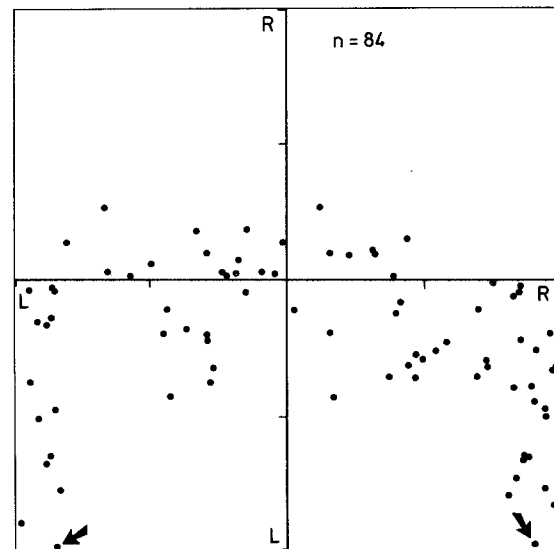

**Fig. 10.** Turning responses of cockroaches with rotated cerci. Angle of turn vs. stimulus angle plotted as in Fig. 4. Animals were kept in inverted cups. Both cerci had been rotated clockwise as viewed from above (see insert). The maximal rotation was 60–70° (right cercus). Because of this rotation, there was an expected discontinuity in the graph at about 110°–120° R. Therefore, data from 120° R to 180° were omitted from the calculation of correlation and regression statistics. Each type of symbol represents the responses of a different animal

therefore generally evoke a turn to the right. Receptors on the cerci, however, would signal that this wind had come from the right. This is because each receptor whose optimal angle in the normal animal is between 0° and 20° R has been shifted by at least 20° to the left (see insert, Fig. 10). Therefore, each of these receptors is now optimally stimulated by wind from the left. But these sensory cells should still produce the same motor response as they would in the normal animal, namely a turn to the left. In fact, the mean angle of turn in response to wind puffs from 0° to 20° L is 20° left.

Second, wind from about 160° R to 180° would be sensed by receptors on the body as coming from the animal's right and would therefore evoke turns to the left. Receptors on the cerci would sense this wind as coming from the left and would therefore evoke turns to the right. In fact, the mean angle for 18 stimuli delivered from between 160° R and 180° was 28° right. Of these 18 stimuli, 8 actually evoked small turns to the left. But 7 of these 8 were responses by one insect. Turns to the right were given by 5 different insects.

The second test for cercal specification of the angle of turn was to cover only the left cercus with wax in otherwise normal animals. This is known to depress



**Fig. 11.** Turning responses of free-ranging cockroaches with left cercus covered. Angle of turn vs. stimulus angle plotted as in Fig. 4. Points indicated with an arrow show turns which were larger than 180°

the responses to wind of left giant interneurons (GI's) 1–6 (but not GI 7) more than their contralateral homologues (Westin et al., 1977). Specifically, in such animals wind puffs from about 130° L to 180°, as well as from 130° R to 180°, excite right GI's 1, 2, 3, 4 and 6 more than their left homologues (but left GI 7 more than its right homologue). Left and right GI's 5 are not activated by these wind directions (Westin et al., 1977). If the cerci provide the angular information for the turn (and if left-right comparisons among giant interneurons are used to discriminate left and right wind sources) one might expect wind from either the left front or the right front to evoke turns to the left when the left cercus is covered. The graph of turning responses by animals with the left cercus covered is shown in Figure 11. The graph includes 25 responses to stimuli from 130° R to 180°, and 15 responses to stimuli from 130° L to 180°. All these stimuli except one evoked turns to the left. Data for wind stimuli from more posterior angles are more difficult to interpret. This is because for these directions the excitation of GI's 3 and 6 decreases, and that of GI 5 increases. Unlike GI's 3 and 6 the responses of left and right GI's 5 are reduced approximately equally by unilateral cercal covering (Westin et al., 1977). Therefore, covering one cercus introduces less overall lateral biasing of the GI response for posterior than for anterior sources of wind.

To summarize, since manipulation of the cerci fully controlled the insect's angle of turn, the cerci

appeared to provide the only important directional information by which the cockroach oriented away from our wind stimuli. Somewhat surprisingly, these posteriorly located sensory structures even mediated the insect's response to wind from the front (Figs. 8, 10, 11).

#### Leg Movements During the Turning Response

The movements of the metathoracic legs were analyzed in normal, free-ranging cockroaches executing turning responses away from the source of wind. The metathoracic legs are the largest, probably the most powerful, and were the easiest to observe on our films. Their movements were of particular interest because of recent experiments which revealed that wind from different directions excites different giant interneurons which, in turn, excite different sets of metathoracic leg motor neurons (Westin et al., 1977; Ritzmann and Camhi, 1978). We wished to determine whether the leg movements observed in intact animals correlate with these neurophysiological findings.

The most common initial movements made by a metathoracic leg in response to wind from ipsilateral  $0^\circ$  to  $70^\circ$  was a retraction; that is, a push by the leg backward against the ground (Fig. 12A). This is consistent with the neurophysiological data, since wind from these angles excites ipsilateral giant interneuron 5, which in turn excites primarily a main retractor-depressor motor neuron of the ipsilateral metathoracic leg (Westin et al., 1977; Ritzmann and Camhi, 1978). Wind from ipsilateral  $70^\circ$  to  $180^\circ$ , however, evoked an initial protraction (forward swing) of the metathoracic leg (Fig. 12A). Wind from these angles excites not GI 5 but GI 6, which in turn excites primarily the protractor-levator motor neurons of the ipsilateral metathoracic leg (Westin et al., 1977; Ritzmann and Camhi, 1978). Of the 7 GI's identified in each connective, numbers 5 and 6 are the ones which showed both the greatest directionality in their response to wind and an ability to excite leg motor neurons. Therefore, the movements of the ipsilateral metathoracic leg were consistent with the neurophysiological findings.

The initial movement of a metathoracic leg was variable for wind from contralateral  $0^\circ$  to  $70^\circ$ . However, for wind from contralateral  $70^\circ$  to  $180^\circ$ , the metathoracic tarsus remained fixed on the ground and served as the pivot point about which the animal turned (Fig. 12B). This pivot remained fixed while the body turned through angles up to  $100^\circ$ , and while the opposite metathoracic leg made up to  $2\frac{1}{2}$  complete stepping cycles. The motor output responsi-

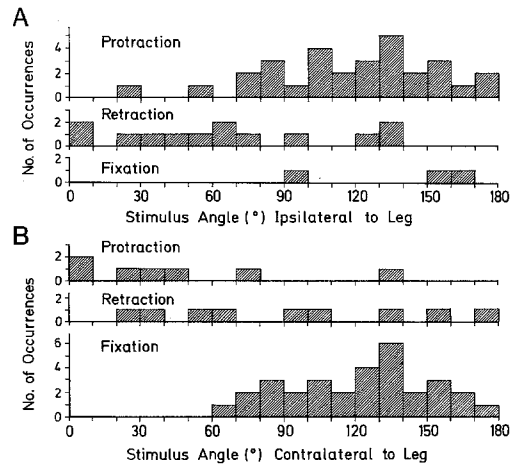

**Fig. 12A and B.** Initial movement of each metathoracic leg in response to wind from different directions; free-ranging cockroaches. **A** Source of wind ipsilateral to leg observed. **B** Source of wind contralateral to leg observed. Movements were determined on the first ciné frame which showed any detectable movements of the body. Definitions: *Protraction*, tarsus moves with respect to the ground in an anterior direction. *Retraction*, tarsus does not move with respect to the ground; also, angle of the femoral-tibial joint increases. (With this action the leg pushes backward against the ground.) *Fixation*, tarsus does not move with respect to the ground; angle of femoral-tibial joint remains the same or decreases. (With this action, the leg serves as the pivot point of the insect's turn.) These data are only from trials where cockroaches turned away from wind source; that is, 44 of the total of 54 trials

ble for fixing the tarsus on the ground as a pivot point is unknown.

#### Open Loop vs. Closed Loop Turning Behavior

The giant interneurons and other interneurons convey information about the direction of a wind stimulus from the cerci to the thoracic ganglia (Westin et al., 1977). This information could, in principle, be adequate to command the proper direction and magnitude of a turn (i.e., open loop response). However, sensory feedback information generated during the turn might also be required for executing a proper turn (i.e., closed loop). Such interactions of sensory commands with feedback information are common in orientation movements (Hinde, 1970). Our stop-frame analysis suggested that sensory feedback during the turn played at best a minimal role in determining the direction and magnitude of the turn. This is because both the direction of the leg movements and the direction of the body's turn, as seen on the first cine frame of the insect's movement, depended upon wind angle (Figs. 12, 13). This first frame captures the insect's position, on different trials, at some moment between 0 and 16 ms (on average, 8 ms) after

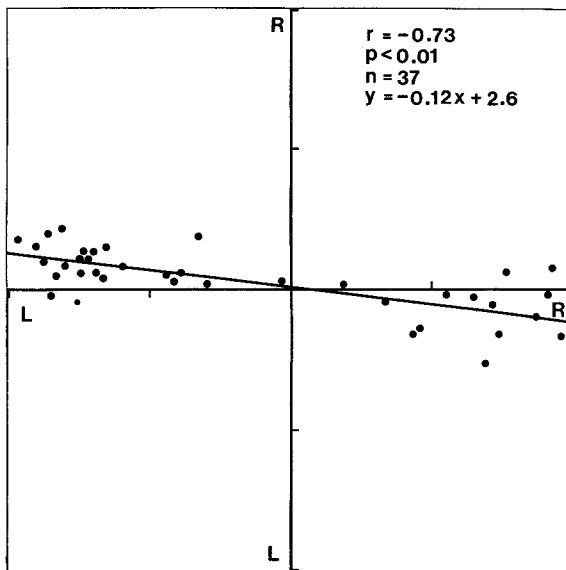

Fig. 13. Turning responses of free-ranging cockroaches; first frame of movement only. Angle of turn plotted by the convention shown in Fig. 4. Same animals as in Fig. 5

the onset of the turn. Within this time, sensory feedback is unlikely to have been generated, been centrally integrated, and begun to influence the insect's behavior.<sup>2</sup> Therefore, the cockroach presumably does not have time to begin a turn, determine through sensory feedback whether the turn is in the wrong direction, and then correct any wrong turns. This analysis is consistent with the idea that the escape behavior is executed in an open loop manner.

A similar analysis was carried out for the second inter-frame interval of the insect's movement. (On most trials, the insect moved throughout this entire interval.) The amount of turning achieved in this interval was significantly greater for input angles of 90–180° than for 0–90°. (Data from left and right sides summed;  $p < 0.001$ , Student's  $t$  test). This indicates that the motor output which is commanded by a larger stimulus angle is a turn of higher angular velocity.

## Discussion

This study has shown that the cockroach *Periplaneta americana* responds to a wind puff with a stereotyped pivot away from the source of wind. This stereotypy is indicated by three factors: (1) the direction of the

<sup>2</sup> The shortest known sensory-to-motor latency in the cockroach is that of trochanteral hair cells exciting leg motor neuron Ds. The latency from mechanical input to movement output has not been directly measured. However, based upon the latency measurements made of parts of this reflex, the overall latency is probably more than 10 ms and possibly much more (Wong and Pearson, 1976)

turn is consistent for a given stimulus angle (e.g. Fig. 6); (2) the slope of the regression line is nearly the same for different groups of cockroaches left under the cups and given the same wind stimuli (Figs. 6, 9, 10); (3) the initial movements made by the metathoracic legs are consistent for most angles of stimulation (Fig. 12). After the initial pivot, the insect's turning behavior is more variable (Fig. 3). A similar change from initial stereotyped movements to subsequent variable movements has been reported in the escape behaviors of both the crayfish (Wine and Krasne, 1972), and teleost fish (Eaton et al., 1977). Therefore, this may represent a common characteristic in escape systems.

A variety of considerations suggests that the initial pivot may be mediated at least in part by the insect's giant interneurons (GI's): (1) receptors located on the cerci are necessary for wind both to evoke the turning behavior and to excite action potentials in 14 identified GI's (Westin et al., 1977). (2) 10 of the 14 identified GI's are directionally selective to wind, and thus could convey the information needed to orient the initial pivot (Westin et al., 1977). (3) Stimulating individual GI's with trains of action potentials evokes action potentials in metathoracic leg motor neurons (Ritzmann and Camhi, 1978). (4) The specific inputs and outputs of identified GI's correlate with the insect's behavioral responses to wind. For instance, GI 6 is excited by wind from the ipsilateral front and, in turn, excites protractor motor neurons of the ipsilateral metathoracic leg (Westin et al., 1977; Ritzmann and Camhi, 1978). In the intact insect, wind from the ipsilateral front evokes an initial protraction of this leg (Fig. 12A). Similar correlations are seen for GI 5. (5) The identified giant interneurons have the largest diameter, and therefore fastest conducting axons in the abdominal nerve cord (Parnas and Dagan, 1971). This makes them suitable for evoking escape responses, where a short latency presumably is important.

We have shown that the direction of the cockroach's turn and the direction of the leg movements are correlated with stimulus angle, even when sampled on the first frame of the movement (Figs. 12, 13). This frame probably catches the action prior to the time when feedback information from the turn itself could contribute to the behavior. One implication of this result is that the giant interneurons and other, unidentified, neurons ascending the cord from the terminal abdominal ganglion contain all the information necessary to specify the size and direction of the turn. This should simplify the attempt to elucidate the neural mechanisms by which the turn is specified.

The behavior which we have described shows some resemblance to wind-evoked orientation behaviors in *Periplaneta americana* which have been



reported by others (Rust et al., 1976). *Periplaneta* walking on a 3-dimensional Y-maze has been shown to turn away from a source of continuous wind. If female sex-attracted pheromone is added to the wind stimulus, adult male cockroaches turn up-wind. It seems unlikely, however, that these responses were mediated by the giant interneurons, since the wind stimulus was continuous—a situation which should lead to rapid adaptation of the GI response (Westin et al., 1977). Moreover, the turning response on the Y-maze persisted for a long while, and therefore was different from the brief initial pivot which we describe in this paper.

The cockroach's evasive response differs from most other escape behaviors studied in that it is more directional. For instance, the initial trajectory of the crayfish escape behavior is either backward or upward, depending upon where the animal is touched (Wine and Krasne, 1972). By contrast, the cockroach can escape in many different directions. These escape movements reveal that this insect's nervous system can discriminate wind directions differing by no more than about 20° (e.g., 170° L vs. 170° R; Figs. 5–7, 9, 11, 12). Nevertheless, the cercal wind receptors and even the most directionally selective GI's respond to a rather broad range of wind directions. Graphs of their activity resemble cosine functions, being responsive from a total of about 180° (Nicklaus, 1965; Westin et al., 1977; Westin, in prep.). Therefore, further sharpening of the directional information conveyed by the GI's is implicated. This would presumably entail some form of comparison of the activity among different GI's. The misdirected turns which we observed in cockroaches having one cercus covered are consistent with a comparison between left and right GI's in discriminating wind puffs from the left front vs. right front. Sharpening of directionality by bilateral comparison is known to occur in the auditory systems of such diverse organisms as crickets, frogs, owls, cats and humans (for reviews see Erulkar, 1972; Konishi, 1977). The cockroach escape system, with its individually identified sensory neurons (Nicklaus, 1965), giant interneurons (Westin et al., 1977) and motor neurons (Pearson and Fourtner, 1973) may serve as a useful model system for understanding this process of directional localization at the cellular level.

We thank Dr. Z. Warhaft for aerodynamic advice, and Dr. R. Ritzmann, Dr. E. Sherman, N. Vardi, S. Volman and Dr. J. Westin for reading the manuscript. This research was supported by NIH grant NS09083, and NSF Grant BMS 76-03067 A01

## References

- Bullock, T.H., Horridge, A.: Structure and function in the nervous systems of invertebrates. San Francisco: Freeman 1965
- Callec, J.: Synaptic transmission in the central nervous system of insects. In: Insect neurobiology. Treherne, J. (ed.), pp. 120–185. New York: American Elsevier 1974
- Camhi, J., Tom, W., Volman, S.: The escape behavior of the cockroach *Periplaneta americana*. II. Detection of natural predators by air displacement. *J. comp. Physiol.* **128**, 203–212 (1978)
- Eaton, R., Bombardieri, R., Meyer, D.: The Mauthner-initiated startle response in teleost fish. *J. Exp. Biol.* **66**, 65–81 (1977)
- Erulkar, S.: Comparative aspects of spatial localization of sound. *Physiol. Rev.* **52**, 273–360 (1972)
- Gnatzy, W.: The ultrastructure of the thread-hairs on the cerci of the cockroach *Periplaneta americana* L.: The intermoult phase. *J. Ultrastruct. Res.* **54**, 124–134 (1976)
- Hinde, R.: Animal behavior: A synthesis of ethology and comparative psychology. New York: McGraw-Hill (1970)
- Konishi, M.: Spatial localization of sound. Dahlem Konferenzen **5**, 127–143, (1977)
- Nicklaus, R.: Die Erregung einzelner Fadenhaare von *Periplaneta americana* in Abhängigkeit von der Grösse und Richtung der Auslenkung. *Z. vergl. Physiol.* **50**, 331–362 (1965)
- Parnas, I., Dagan, D.: Functional organization of giant axons in the central nervous systems of insects: new aspects. *Adv. Insect Physiol.* **8**, 95–143 (1971)
- Pearson, K.G., Fourtner, C.R.: Identification of the somata of common inhibitory motoneurons in the metathoracic ganglion of the cockroach. *Can. J. Zool.* **51**, 859–866 (1973)
- Ritzmann, R.E., Camhi, J.M.: Excitation of leg motor neurons by giant interneurons in the cockroach *Periplaneta americana*. *J. comp. Physiol.* **125**, 305–316 (1978)
- Roeder, K.: Organization of the ascending giant fiber system in the cockroach (*Periplaneta americana*). *J. Exp. Zool.* **108**, 243–261 (1948)
- Roeder, K.: Nerve cells and insect behavior. Cambridge, Massachusetts: Harvard University Press 1963
- Rust, M., Burk, T., Bell, W.: Pheromone-stimulated locomotory and orientation responses in the American cockroach. *Anim. Behav.* **24**, 52–67 (1976)
- Westin, J., Langberg, J., Camhi, J.: Responses of giant interneurons of the cockroach *Periplaneta americana* to wind puffs of different directions and velocities. *J. comp. Physiol.* **121**, 307–324 (1977)
- Wine, J.J., Krasne, F.B.: Organization of escape behaviour in the crayfish. *J. Exp. Biol.* **56**, 1–18 (1972)
- Wong, R., Pearson, K.: Properties of the trochanteral hair plate and its function in the control of walking in the cockroach. *J. Exp. Biol.* **64**, 233–249 (1976)